

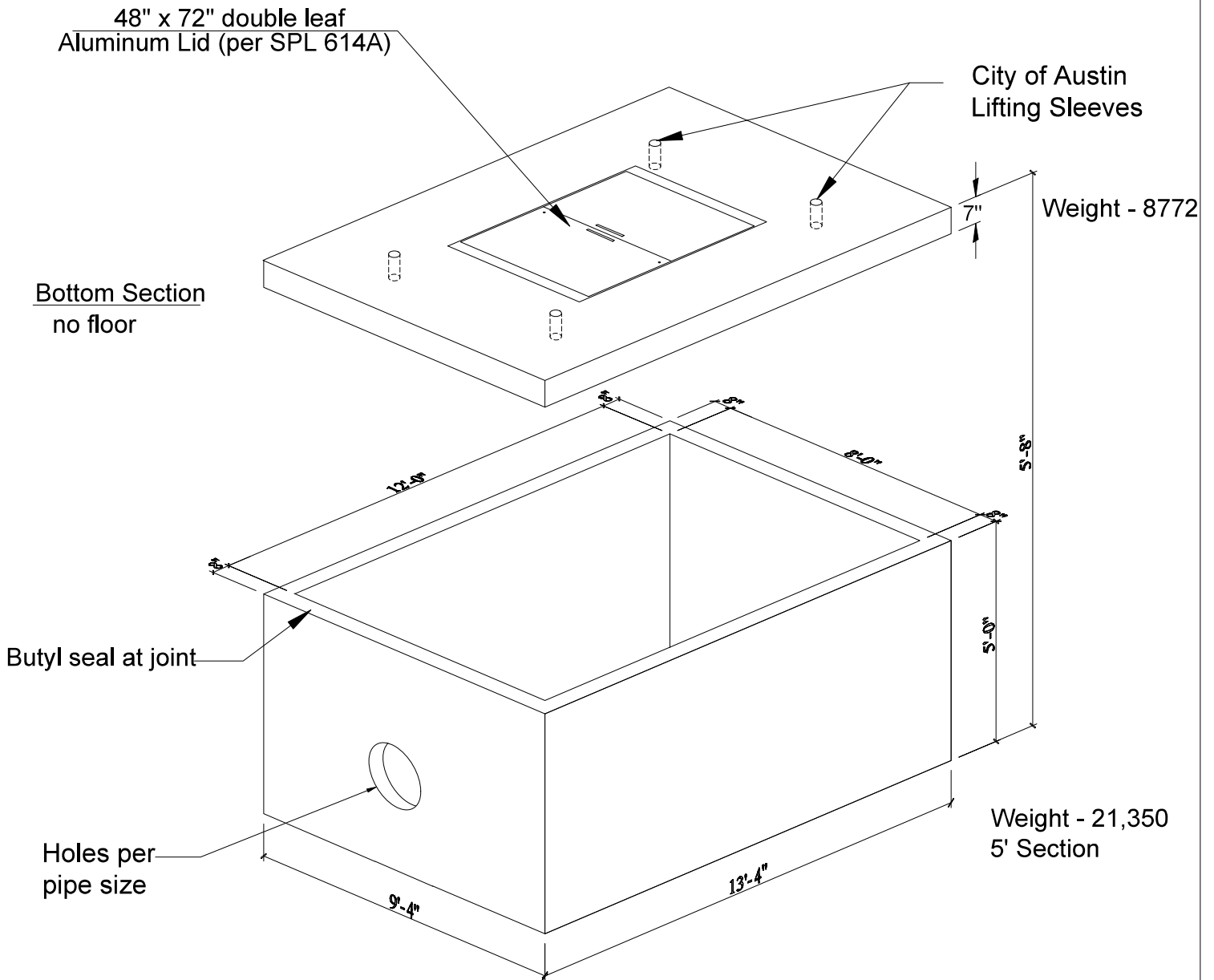

8' x 12' Meter Vault with 48" x 72" H2O Aluminum Lid (per Austin Specifications)



Specifications:

- Concrete has a 28 day strength of 5,000 psi
- Steel reinforcement is ASTM A615 Grade 60
- Load design is H-20

 <p>Lone Star Precast 454 Kelly Smith Lane Buda, Texas 78610 Ph: 512.312.2121</p>	 <p>NPCA CERTIFIED PLANT</p>	TITLE 8' x 12' Austin Meter Vault		
		PART NO -	DWG NO -	REV
DRAWN VAC	DATE 02/13/2023	SCALE 1 / 40	Dimensions Unit: inch	SHEET 1 OF 1